

Percival Mew Gull E.3H

Captain E. W. Pecival

Ref.: AR.720300

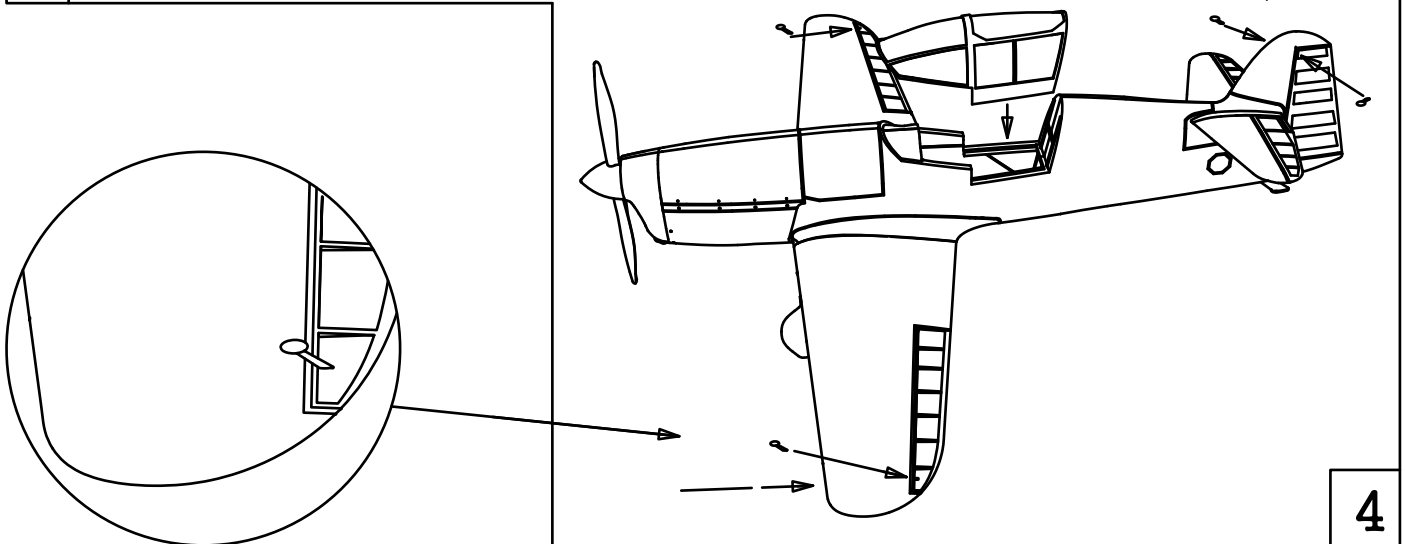
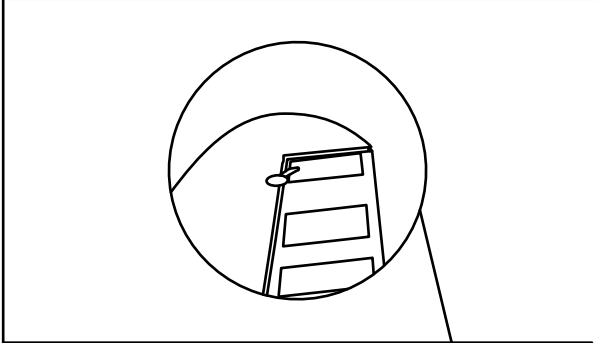
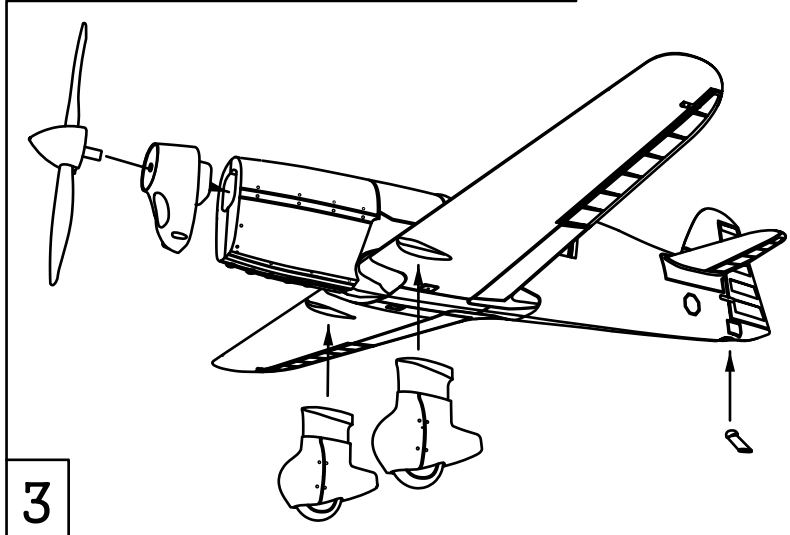
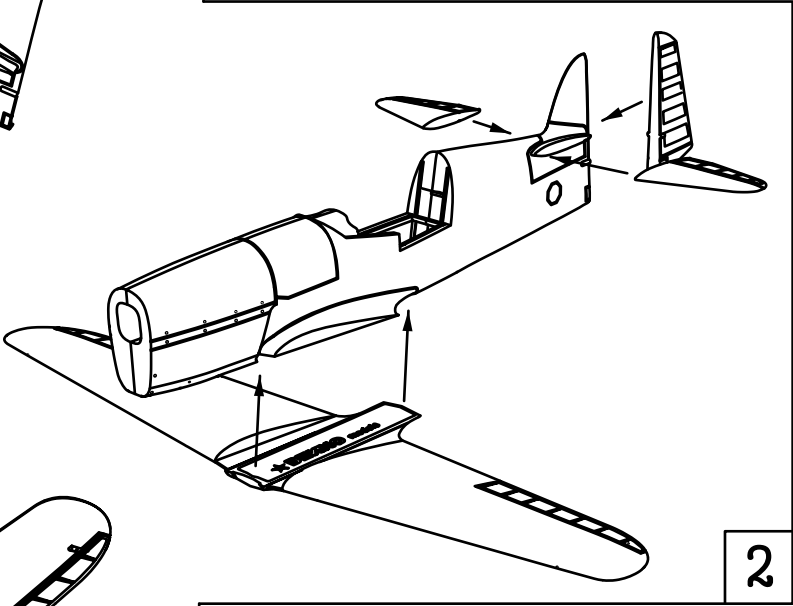
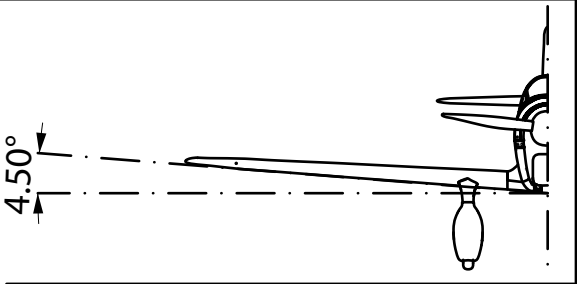
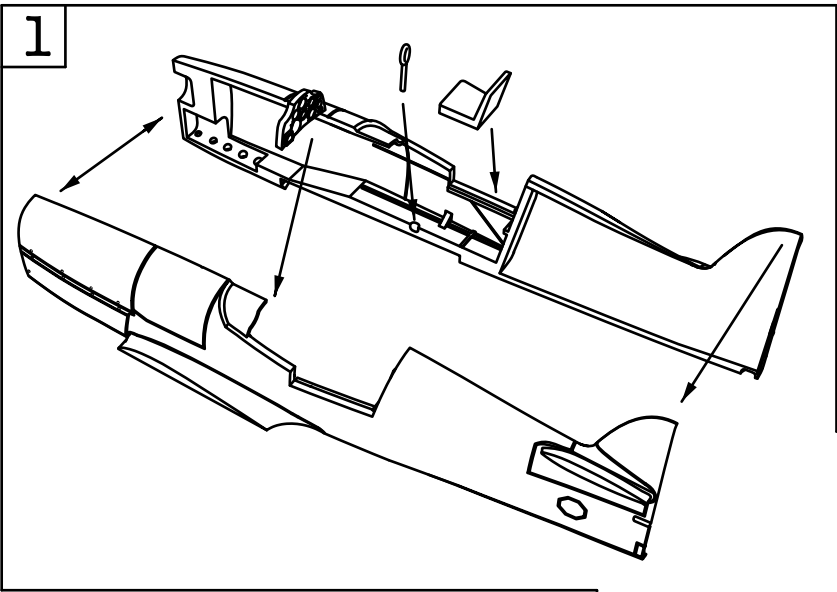
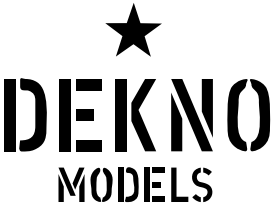

Percival P.6 Mew Gull E.3H

1938 King's Cup Race version

Pilot: Captain E.W. Percival

COLORS:

Interior - Humbrol #78

Gloss white overall "broken white"

Spinner and propeller - Polished aluminum

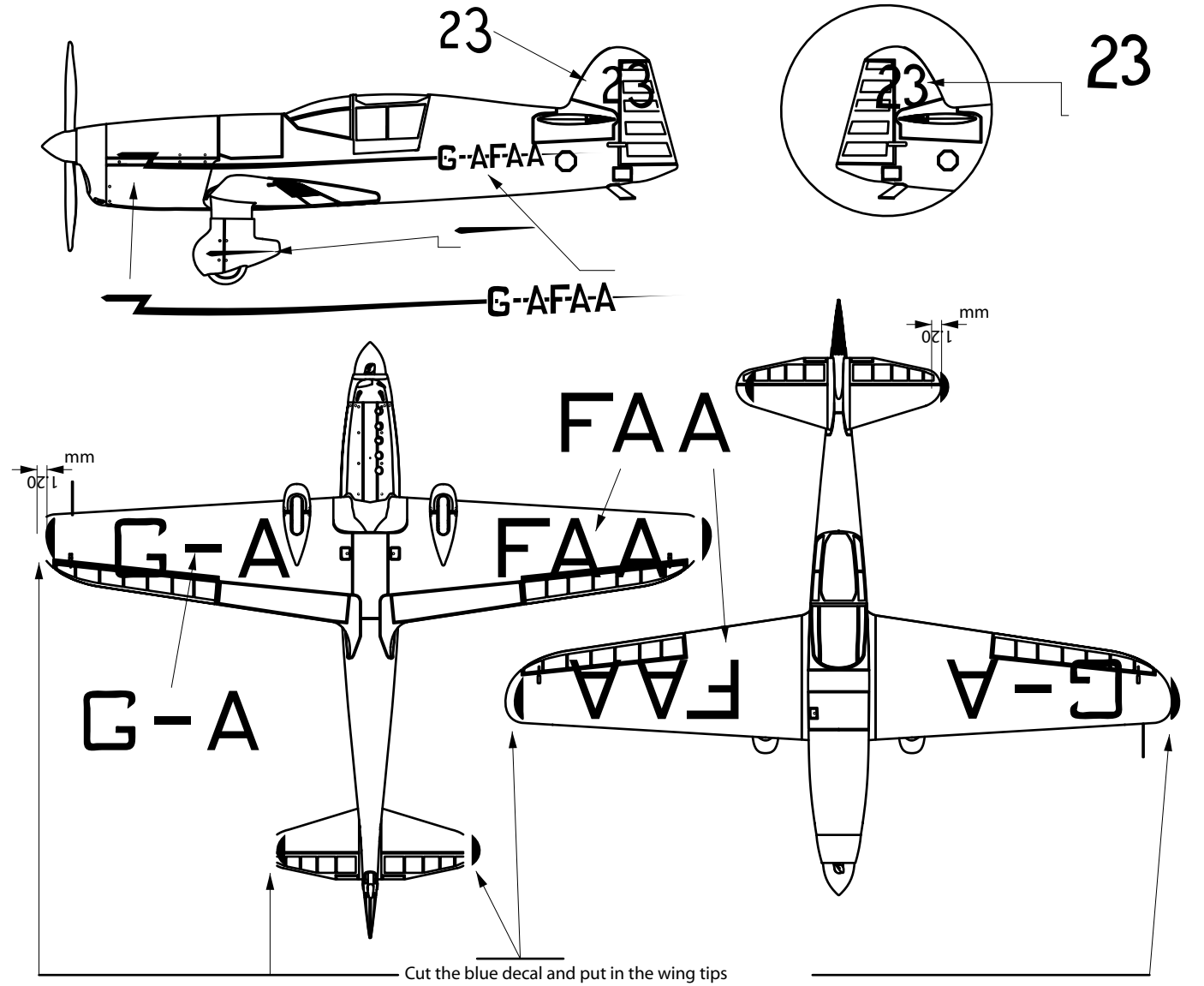

The one-off Type E.3H (the so-called "Super"-Mew) was Edgar Percival's personal mount. While looking very much the same as the E2H, this was actually a completely new design, powered by a Gipsy Six Series II. It first flew in 1937 and was raced by Percival in 1937–1939. On loan for propeller trials at Hatfield during the war, G-AFAA was written off in a landing accident by a de Havilland pilot. The remains of this aircraft were burned with those of G-ACND at a Percival Aircraft garden fete at Luton Airport immediately after the war.
Source: http://en.wikipedia.org/wiki/Percival_Mew_Gull#G-AFAA